



STANDARD DETAILS FOR TILE ROOF PATIO COVERS

Pre-engineered details for a patio cover that is attached to a residential structure.

In order to use this pre-engineered standard **no deviation** from this handout will be allowed. For example but not limited to cantilevered second floors, structure or window pop-outs, or ledgers extended beyond the structure.

Provide a plot plan. See handout for "How to prepare a residential plot plan".

SUBMITTAL REQUIREMENTS

- Completed Building Permit Application
- Three (3) copies of plans prepared to a standard scale
- Complete sets of plans consist of the following:
 - Name of Property owner
 - Assessor parcel number, tract number, lot number
 - All property lines with dimensions
 - Drawn to scale
 - All structures, provide setback dimensions to all property lines (front, sides and rear)
 - Identify and show easements, *if any*
- Signed Carbon Monoxide/Smoke Detector Form (must be signed by the **HOMEOWNER**, not the contractor)
- Calculate the tributary area of the patio cover in order to circle the proper footing size on the following pages
- Circle items and fill in the distances on the following pages

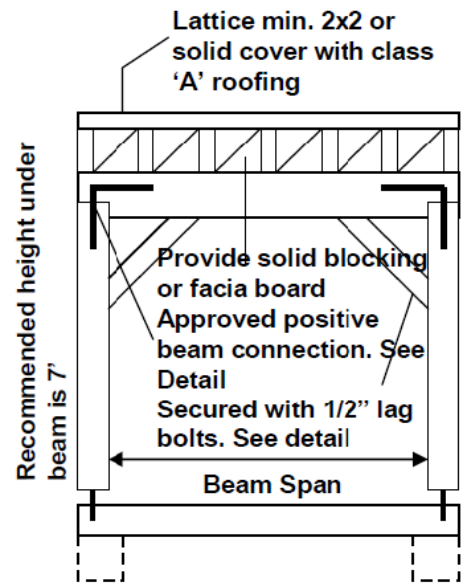
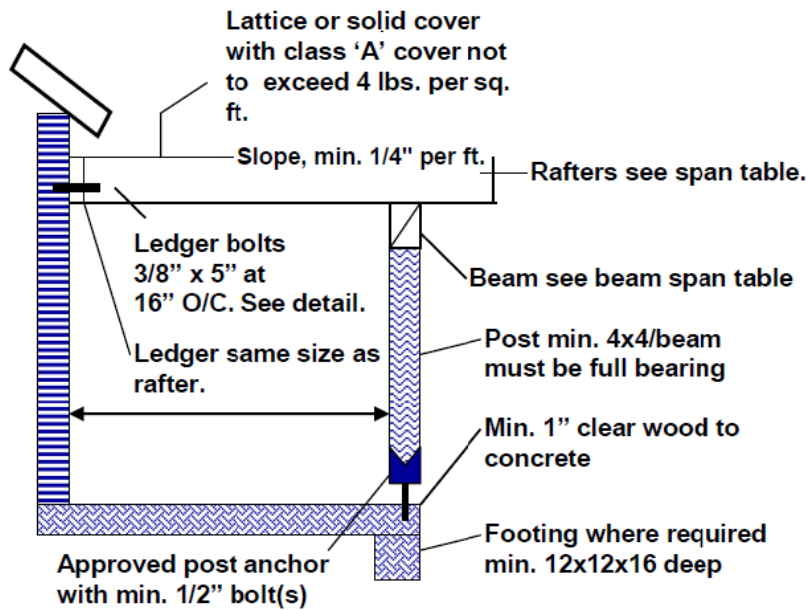

	Example 10 x 20 patio tributary area to end post = 1/2 length from house to beam and 1/2 length from post to post or $5 \times 5 = 25$ no footing middle post 1/2 house and 1/2 each post or $5 \times (5 + 5) = 50$ no footing required	
L/2	Middle post L/2 from each post or L/2 + L/2 Tributary area to post see footing table	L/2
	L/2 ——— l ——— L/2	

Footing Table

Trib area -----	footing size
0 to 52 -----	none req.
52 to 85 -----	12 x 12 x 16
85 to 116 -----	14 x 14 x 16
116 to 152 -----	16 x 16 x 16
152 to 193 -----	18 x 18 x 18

Notes:

1. Post anchors have to be embedded into footing concrete with post support 1 inch above patio slab.
2. Ledger board shall be attached to the house with minimum 3/8" x 5" lag bolts staggered -- spaced 16" on center.
3. Patio rafters shall be attached to ledger board with approved joist hangers. Block joists at each end.
4. No attachment shall be made to masonry/brick fireplaces chase or to truss system.
5. Post/beam connection shall be made by mechanical means. All holes filled through bolted and/or nailed as applicable.
6. All work shall conform to the 2010 California Residential Code.

Although not required, recommended welded wire fabric be placed in patio slabs in expansive soils area.

POST AND BEAM

Tile Roof

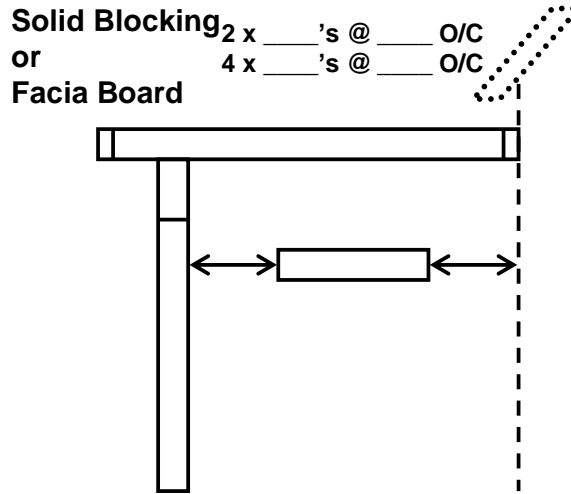
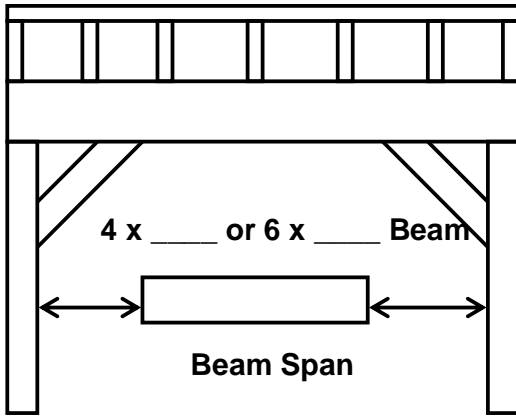

BEAM SPAN TABLE

4 X Beams #2 DF
6 x Beams #1 DF

BEAM SPAN	RAFTER SPAN							
	10'	12'	14'	16'	18'	20'	22'	24'
4'-----	4 X 4	4 X 4	4 X 4	4 X 4	4 X 4	4 X 4	4 X 4	4 X 4
6'-----	4 X 4	4 X 6	4 X 6	4 X 6	4 X 6	4 X 6	4 X 6	4 X 8
8'-----	4 X 6	4 X 6	4 X 8	4 X 8	4 X 8	4 X 8	4 X 8	4 X 10
10'-----	4 X 8	4 X 8	4 X 8	4 X 10	4 X 10	4 X 10	4 X 10	4 X 12
12'-----	4 X 8	4 X 10	4 X 10	4 X 10	4 X 12	4 X 12	4 X 12	4 X 12
14'-----	4 X 8	4 X 10	4 X 12	4 X 12	4 X 14	4 X 14	4 X 14	4 X 14
16'-----	4 X 12	4 X 12	4 X 14	4 X 14	4 X 14	4 X 16	4 X 16	
18'-----	4 X 14	4 X 14	4 X 16	4 X 16	4 X 16	4 X 16	6 X 14	6 X 14
20'-----	4 X 14	4 X 14	4 X 16	4 X 16	6 X 14	6 X 14	6 X 16	6 X 16

RAFTER SPAN

	16"	o/c---13'9"
2 X 6	24"	o/c---11'3"
	12"	o/c---18'9"
2 X 8	16"	o/c---16'3"
	24"	o/c---13'3"
	12"	o/c---23'0"
2 X 10	16"	o/c---19'11"
	24"	o/c---13'3"
	12"	o/c---14'5"
	16"	o/c---12'6"
	24"	o/c---10'3"
4 X 4	32"	o/c---8'1"
	36"	o/c---7'5"
	48"	o/c---6'6"
	12"	o/c---22'3"
	16"	o/c---19'5"
	24"	o/c---15'7"
4 X 6	32"	o/c---12'7"
	36"	o/c---11'10"
	48"	o/c---10'2"

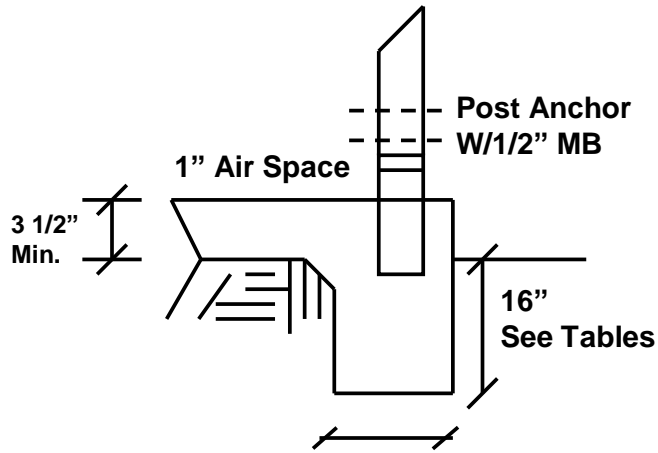

FOOTING DETAIL

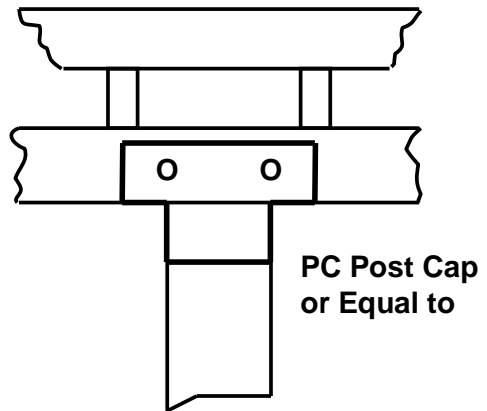

POST TO BEAM

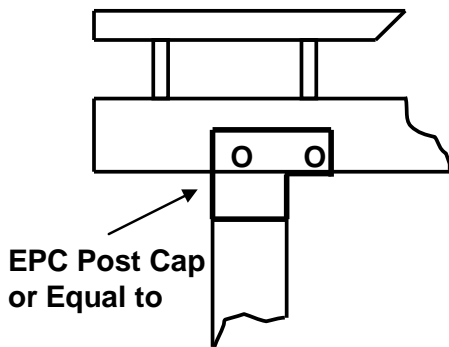

POST TO BEAM

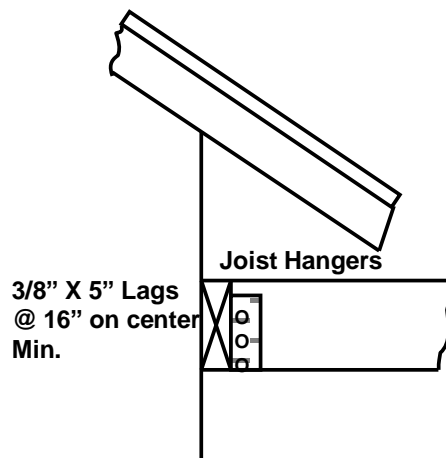

LEDGER DETAIL

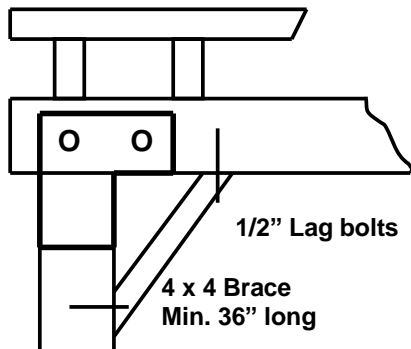

KNEE BRACE DETAIL

**KNEE BRACES ARE REQUIRED
AT ALL POSTS!**